

New Home Plans For:



NOTES

Outside Shell Only

Turn-Key Price



“The Skylark”

3,610 sq ft | 3 Bed + Bonus Room | 2 Bath

50' x 70' Footprint | 28' x 34' Garage |
2,002 sq ft Living Space



www.graberpost.com

800-264-5013

Building Layout

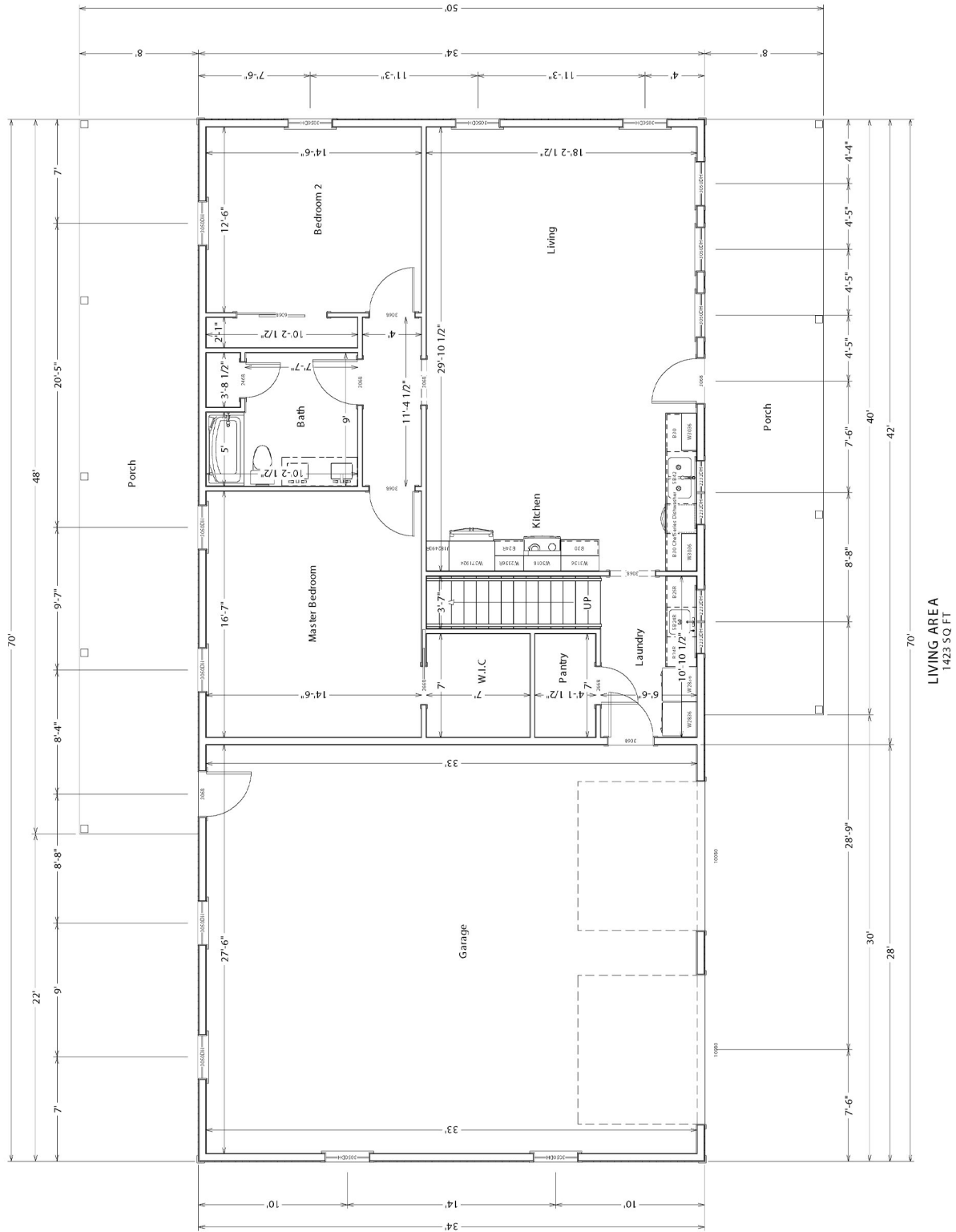

Interior Design

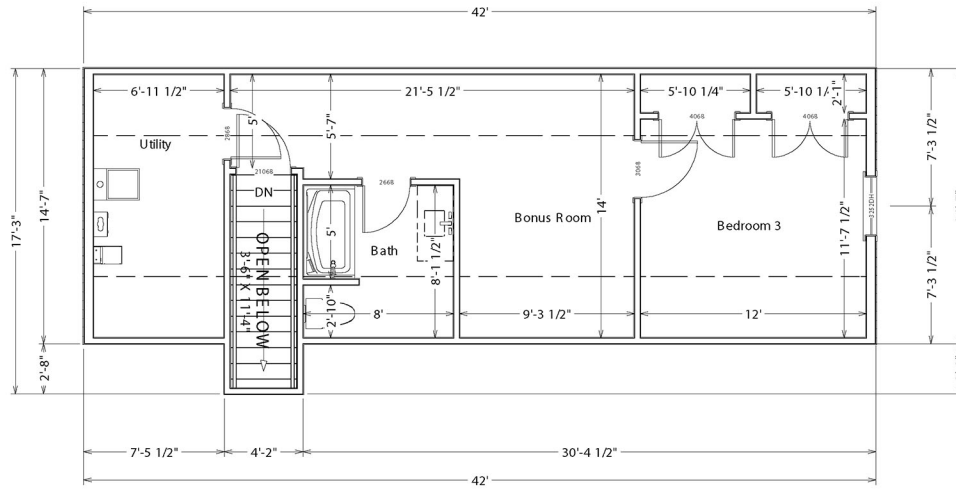

LIVING AREA
579 SQ FT



800-264-5013



Turn these plans into your own!

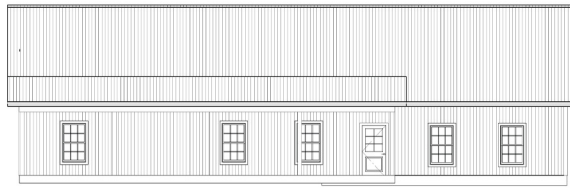
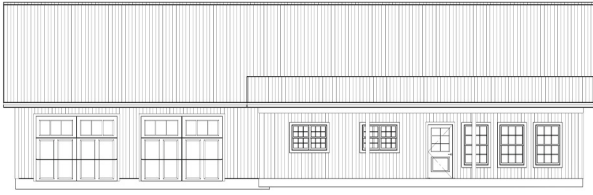

Feel free to customize the plan if it's not exactly what you would like. Our in-house designers have these plans on file and can easily and efficiently customize them to your specs.

Our residential homes are built standard with a concrete footing and conventional stud framing to assure no issues meeting building codes and providing you with peace of mind for many years to come.

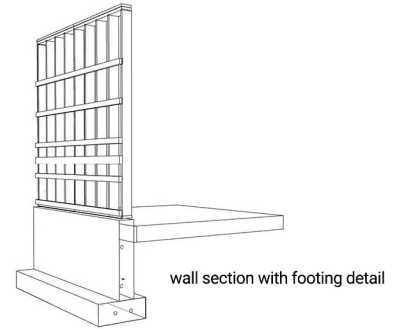

Quality products from start to finish

This specific home design was completed using our elite "GPB" standard products, from the industry leading 40-year warranty painted roofing/siding panels that we roll-form and cut to length in our manufacturing facility. We offer high quality C.H.I insulated overhead doors, and windows that are produced by Pella, both well known companies in the building industry. We offer several stock model entry doors from Therma-Tru that can be custom painted or we can special order specific models to suit your needs.

AkzoNobel



THERMA-TRU
DOORS



LP SmartSide
TRIM & SIDING



www.graberpost.com

800-264-5013